

# Product Information



## 4681TOP125P63

EAN 4031582308037

Swivel caster with directional lock, housing made of very heavy pressed steel, reinforced, bright zinc plated, blue passivated, sealed swivel double ball bearing, reinforced and heat-treated ball covers, riveted king pin, wheel axle with nut. Wheel center made of Polyamide, heavy duty, precision ball bearing, plate fitting

**Hint:** This caster can be fitted with a directional lock. However, the lock does not come as standard and has to be ordered as an added option.



Technical Data	
Wheel diameter	4.92 in
Tread width	1.97 in
Plate size	5.51 x 4.33 in
Plate hole centers	4.13 x 3.15/2.91 in
Plate hole	0.43 in
Offset	2.17 in
Swivel Interference	9.06 in
Overall height	6.46 in
Temperature	- 40 / + 176 °F
Standard	EN 12532
Weight	6.248 lbs
Load capacity (dynamic)	1545 lbs
Load capacity (static)	3085 lbs
Hardness of tread	D 75 Shore

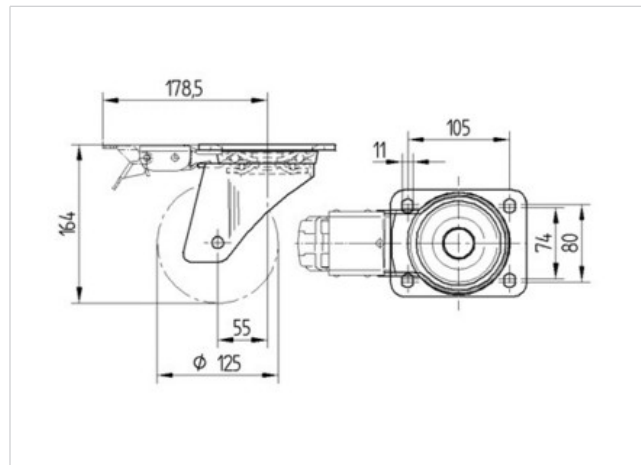

Roll performance	+	+	+	+	+
Movement noise	+	+	+	+	+
Attrition	+	+	+	+	+
Corrosion resistance	+	+	+	+	+

# Product Information



## 4681TOP125P63

EAN 4031582308037

