

Product Information



LINEA

5946UAP150R36-32S300H155

EAN 4031582338928

Swivel caster with central lock, housing made of Polyamide, precision ball bearing in swivel head. Wheel center made of Polyamide, Tread: Polyurethane, precision ball bearing, stem with cam hole for profile bars, short version

Hint:TÜV Süd certified product.

Technical Data

Wheel diameter	5.91 in
Tread width	0.59 in
Caster width	2.80 in
Bolt-Ø	1.26 in
Bolt length	1.97 in
Offset	1.87 in
Swivel Interference	9.65 in
Overall height	6.10 in
Temperature	- 14 / + 104 °F
Standard	EN 12531
Weight	2.425 lbs
Load capacity (dynamic)	330 lbs
Load capacity (static)	660 lbs
Swivel Radius	4.82 in

Roll performance	+	+	+	+	+
Movement noise	+	+	+	+	+
Attrition	+	+	+	+	+
Corrosion resistance	+	+	+	+	+

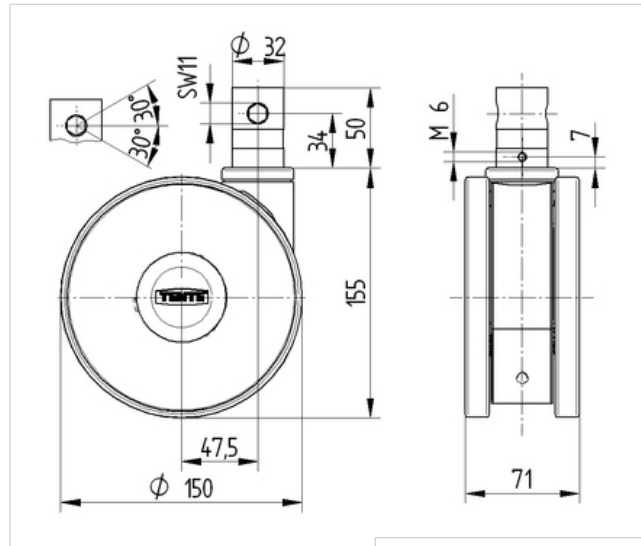

Product Information



LINEA

5946UAP150R36-32S30OH155

EAN 4031582338928

