

# Product Information



## INTEGRAL

### 2046XSX125R36-32S30

EAN 4031582341270

Swivel caster with central lock, Frame made of pressed steel, precision ball bearing in swivel head and wheel, housing cover made of synthetic plastic. Wheel center made of Polyamide, electric conductive, Tread made of injected Polyurethane, with threadguards, precision ball bearing, sealed., stem with cam hole for profile bars, short version  
**Hint:**TÜV Süd certified product.Washable casters must be sealed in the fitting area by the hospital bed manufacturer.



Technical Data	
Wheel diameter	4.92 in
Tread width	1.26 in
Bolt-Ø	1.26 in
Bolt length	1.97 in
Offset	1.38 in
Swivel Interference	7.68 in
Overall height	6.22 in
Temperature	- 22 / + 176 °F
Standard	EN 12531
Weight	2.233 lbs
Load capacity (dynamic)	330 lbs
Load capacity (static)	660 lbs
Swivel Radius	3.84 in
Hardness of tread	D 40 Shore

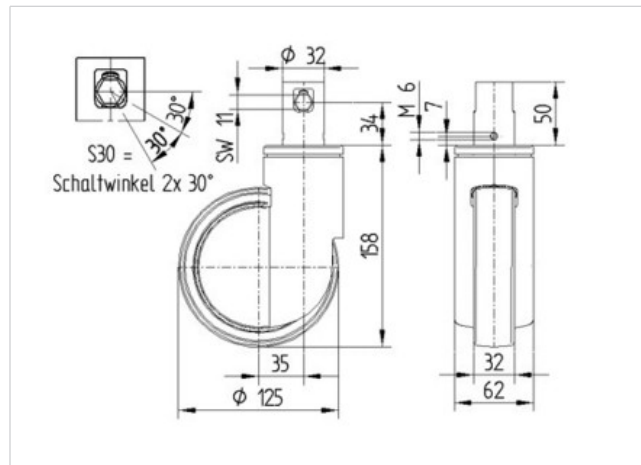

Roll performance	+	+	+	+	+
Movement noise	+	+	+	+	+
Attrition	+	+	+	+	+
Corrosion resistance	+	+	+	+	+

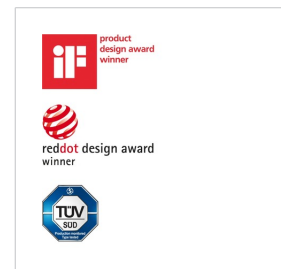

# Product Information



## INTEGRAL

**2046XSX125R36-32S30**

EAN 4031582341270

