

Product Information



LINEA

5944UAP125R36-34XS S30

EAN 4031582348354

Swivel Caster with central, total or directional lock, housing made of Polyamide, precision ball bearing in swivel head. Wheel center made of Polyamide, Tread: Polyurethane, precision ball bearing, stem with cam hole for profile bars, short version

Hint:TÜV Süd certified product.

Technical Data

Wheel diameter	4.92 in
Tread width	0.59 in
Caster width	2.80 in
Bolt-Ø	1.26 in
Bolt length	1.57 in
Offset	1.57 in
Swivel Interference	8.07 in
Overall height	5.12 in
Temperature	- 14 / + 104 °F
Standard	EN 12531
Weight	1.865 lbs
Load capacity (dynamic)	330 lbs
Load capacity (static)	660 lbs
Swivel Radius	4.04 in

Roll performance	+	+	+	+	+
Movement noise	+	+	+	+	+
Attrition	+	+	+	+	+
Corrosion resistance	+	+	+	+	+

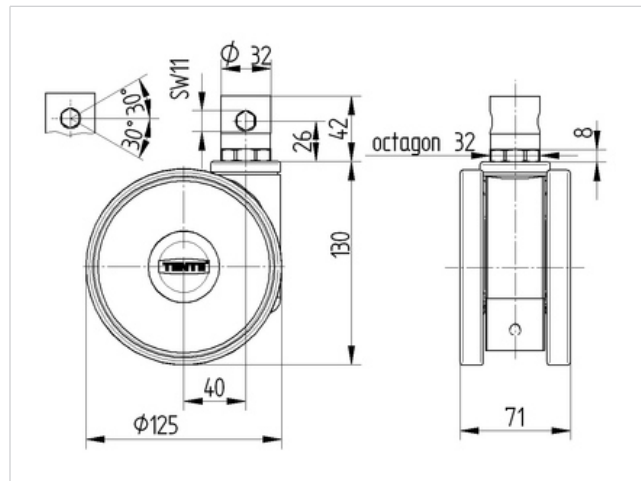

DDC
Design Award Winner
German Designer Club

if product design award winner

interzum award intelligent material & design

Product Information



LINEA

5944UAP125R36-34XS S30

EAN 4031582348354

