

# Product Information



## LINEA

### 5944USC150R36-32S300H155

EAN 4031582360059

Swivel Caster with central, total or directional lock, housing made of Polyamide, precision ball bearing in swivel head. Wheel center made of Polyamide, electric conductive, Tread: Polyurethane, precision ball bearing, stainless, washable, stem with cam hole for profile bars, short version

**Hint:**TÜV Süd certified product. Washable casters must be sealed in the fitting area by the hospital bed manufacturer.

#### Technical Data

Wheel diameter	5.91 in
Tread width	0.59 in
Caster width	2.80 in
Bolt-Ø	1.26 in
Bolt length	1.97 in
Offset	1.87 in
Swivel Interference	9.65 in
Overall height	6.10 in
Temperature	- 14 / + 104 °F
Standard	EN 12531
Weight	2.557 lbs
Load capacity (dynamic)	330 lbs
Load capacity (static)	660 lbs
Swivel Radius	4.82 in

Roll performance	+	+	+	+	+
Movement noise	+	+	+	+	+
Attrition	+	+	+	+	+
Corrosion resistance	+	+	+	+	+

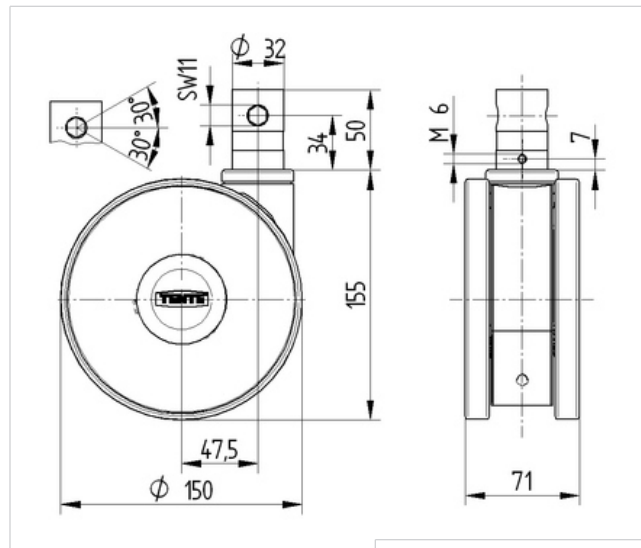

# Product Information



## LINEA

**5944USC150R36-32S300H155**

EAN 4031582360059

